

TDK Electromagnetic Absorbers

Introduction

The compatibility of electronic devices with various electromagnetic environments has become an important issue in recent years. This in turn has greatly increased the number applications which require radio wave absorbing materials in frequencies ranging from the kHz range to millimeter waves in the GHz range.

Applications for such materials include measures for reducing the radiated noise and improving the noise resistance of electronic devices (such as communication devices, office electronics, computers, home appliances, and devices mounted on automobiles), the attenuation of radio wave reflections (such as ETC (the electronic toll collection system), radar's and TV ghost measures) and facilities for evaluating EMI measures (such as anechoic chambers).

TDK offers a wide range of radio wave absorbing materials based on our long tradition of developing electrical and magnetic material technologies as well as electronic and radio wave technologies.

We also accommodate special requests for EMI measures to meet specific conditions. Please let us know what your requirements are.

TDK Electromagnetic Absorbers

CONTENTS	Page
Application Examples of Electromagnetic Absorbers	1
Application Examples and Standard Material	
Characteristics of TDK Electromagnetic Absorbers	3
TDK Material Characteristics	3
Recommended Applications for TDK Electromagnetic Absorbers	4
Descriptions for different TDK products	
For EMC Anechoic Chambers	
IP Material	5
ICM Material	6
IB Material	7
For EMS Floors	
IS-S Material	8
For Microwave Anechoic Chambers	
IS Material	9
IS-SM Material	10
For FM Band and Microwave Anechoic Chambers	
IP-BX Material	11
For EMC/Microwave Anechoic Chambers	
IP Material	12
For Anechoic Chambers used for High-Power Tests	
ICT Material	13
Thin Type	
IR Material	14
ISF Material	17
IJ Material	18
Transparent Electromagnetic Absorbers	
ITB Material	19

 Specifications which provide more details for the proper and safe use of the described product are available upon request.

The information included in this book is subject to change without notice resulting from technical developments and product improvements.

EMC Components Radio Wave Absorbers

APPLICATION EXAMPLES OF ELECTROMAGNETIC ABSORBERS

ANECHOIC CHAMBERS

TDK's radio wave absorbing materials are widely used in anechoic chamber applications. The photos shown here are some examples.



10-meter test range anechoic chamber (uses IP material for radio wave absorption)

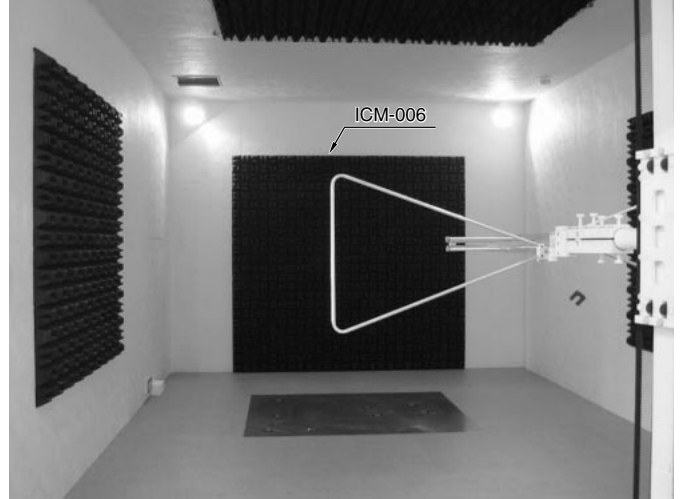

Small-scale anechoic chamber (uses ICM material for radio wave absorption.)

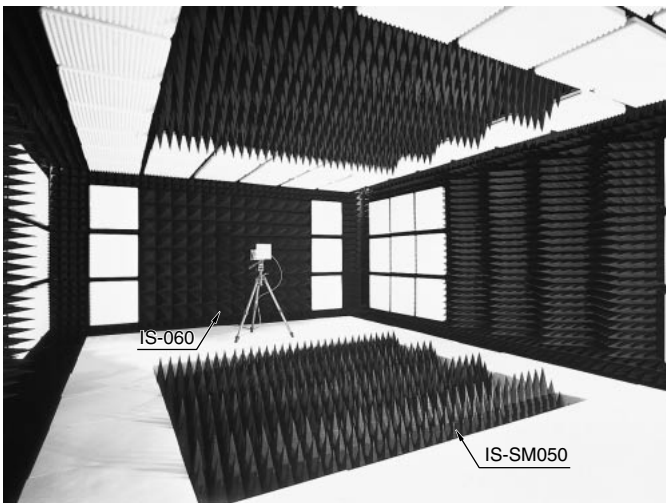

Anechoic chamber for antenna evaluation (uses IS and IS-SM materials for radio wave absorption)

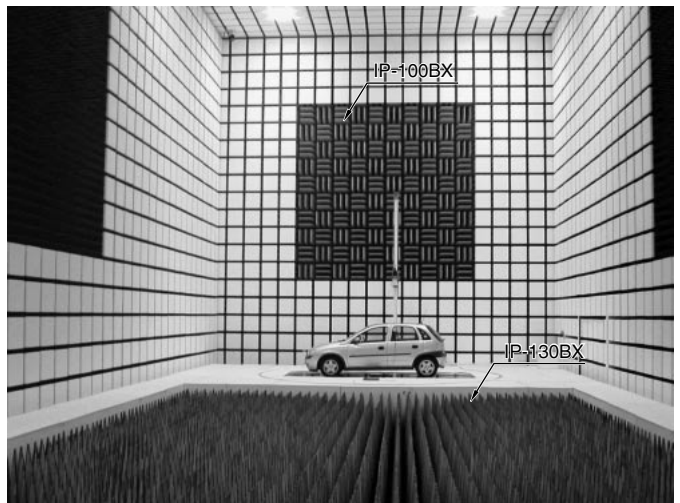

Anechoic chamber for antenna evaluation (uses IP-BX material for radio wave absorption)

• All specifications are subject to change without notice.
• It may not be allowed to export these absorbers due to Export Control regulations.

PREVENTION OF FALSE IMAGE FROM A SHIP'S MAST

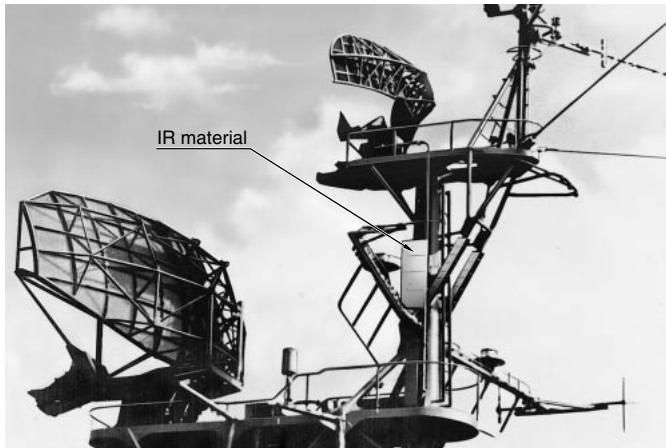

The photo shows the installation of TDK IR material on the main mast of a ship. This prevents false radar images from occurring by greatly reducing the amount of reflection taking place.

PREVENTION OF TV GHOST (IB MATERIAL)



The Tokyo Metropolitan Hall building uses ferrite tiles to reduce TV ghosts.

IMPROVE ETC COMMUNICATION ENVIRONMENTS



This is an example of electromagnetic absorbent panels (ISFE27F5) for ETC systems (Electronic Toll Collection System) installed at an ETC facility to improve the electromagnetic environment.

PREVENT INTERFERENCE BETWEEN ETC LANES



This is an example of transparent electromagnetic absorbent panels (ITB010 and ITB390) for ETC (Electronic Toll Collection) installed between ETC lanes.

A key factor in absorbing unwanted electromagnetic energy efficiently and completely is selecting the most appropriate materials for the application. This selection process must take into account the device or system being interfered with, its operating conditions, and the ambient environment. It is not sufficient to merely choose any products, which absorb electromagnetic energy of the correct frequency range.

SELECTION GUIDELINE OF ELECTROMAGNETIC ABSORBERS

Application	EMC anechoic chambers	3-meter/10-meter test range Compact (3-meter test range)	TDK material name
Radio wave anechoic chambers		Car antenna	IP, IB, ICM
		Antenna evaluation	IP, IB, ICM
	Microwave anechoic chambers	High-power examination	IP-BX, IB, IS
			IS, IS-SM
			ICT
Prevents TV ghosts			IB
Improvement of ETC communication environment			ISF, IJ, ITB
Prevents false radar image			
Prevents parabolic antenna side lobe			IR, ISF, IJ, ITB
Prevents unnecessary radiation			

TDK STANDARD MATERIAL CHARACTERISTICS

TDK material name	IP, IP-BX	ICM	IB	IS, IS-SM	ICT
Features	Ultra wide-band Relatively thin type Fire retardant	Ultra wide-band Ultra thin Nonflammability	Wide-band Thin type Nonflammability	Ultra wide-band Thin type(only for oblique incidence) Fire retardant	Ultra wide-band Thin and lightweight Nonflammability
Applicable frequency range	30MHz min.	30MHz to 18GHz	30MHz to 1.5GHz	300MHz min.	300MHz min.
Basic composition	Carbon+styrofoam	Ferrite+ inorganic material	Sintered ferrite	Carbon+ polyethylene	Carbon+ nonflammable material
Composite material	IB	IB	IP, IP-BX, ICM		
Standard shape	Wedge form Pyramid form	Wedge form	Board	Pyramid form Special pyramid form	Pyramid form
Standard dimension (mm)	600×600×T	100×100×T	100×100×T 60×60×T	600×600×T 600×840×T	150×150×T 300×300×T
Operating temperature range(°C)	-40 to +60	-40 to +150	-40 to +100	-40 to +60	-40 to +300

LIST OF TDK THIN TYPE ELECTROMAGNETIC ABSORBERS

TDK material name	IR	ISF	IJ	ITB
Features	Thin Flexible	Lightweight Fire retardant	Thin Weather resistant	Thin Transparent
Applicable frequency range	700MHz to 30GHz	800MHz min.	1 to 30GHz	800MHz min.
Basic composition	Magnetic material+ synthetic rubber	Carbon+ styrofoam	Magnetic material+ straight-chain polyethylene	PET+ITO film
Standard dimension(mm)	300×300×T	500×500×T	L×1000×T	L×1000
Operating temperature range(°C)	-40 to +80	-40 to +60	-40 to +80	-40 to +80

- All specifications are subject to change without notice.
- It may not be allowed to export these absorbers due to Export Control regulations.

RECOMMENDED APPLICATIONS OF ELECTROMAGNETIC ABSORBERS DESIGNED FOR EMC ANECHOIC CHAMBERS AND MICROWAVE ANECHOIC CHAMBERS

EMI measurement distance	Recommended chamber length	ICM	IP-BL series					IP series			IP-BX series			EMS		
		006 IB-015	045C IB-015	065 IB-015	090 IB-015	130 IB-015	045E IB-015	100B IB-015	150B IB-015	045 X-131	100 X-131	130 X-131	26MHz ICM006	26MHz IP045C	80MHz ISO80S	
Compact (3-meter test range)	7m	○	○										○	○	○	
3-meter test range	9m	○		○									○	○	○	
	10m				○								○	○	○	
10-meter test range	19 to 22m				○								○	○	○	
	22 to 27m				○	○							○	○	○	
ANT and 3-meter test range	7m						○									
EN	8 to 15m	○	○	○	○											
EN and 3-meter test range	8 to 15m	○	○	○	○											
ETSI	11 to 15m		○					○	○							
ETSI and EN	11 to 15m		○					○	○							
Car antenna	10 to 15m									○	○					
	20 to 30m									○	○	○				
	30 to 50m									○		○				

Antenna measurement distance	Length of anechoic chamber	QZ size ϕ (m)	IS series					IS-SM series			IS series				ICT series	
			030A	045	060	075	100	050	080	100	005A	012A	015A	023A	012	030
3m	6 to 8m	0.3 to 1.0	○	○				○								
5m	10 to 12m	1.0 to 1.5	○	○	○			○	○							
10m	15 to 20m	1.5 to 2.5		○		○			○	○						
20m	30 to 35m	2.5 to 4.0		○	○		○		○	○						
Millimeter waves	5m max.	0.3									○	○				
	6 to 8m	0.3 to 1.0											○			
	10 to 12m	1.0 to 1.5	○					○						○		
Cellular phone	5m max.	0.3	○									○	○	○		
High power	5m max.	0.3 to 0.6													○	
	6 to 10m	0.3 to 1.5													○	○

RECOMMENDED APPLICATIONS OF THIN TYPE ELECTROMAGNETIC ABSORBERS

Recommended application	Object	Recommended frequency range	IB series			IR series				ISF series				ITB material	IJ material
			015	003	004	B	A	K	E	B55	B75	A24	E5F27	010/390	058
			Sintered ferrite			Composite ferrite		Composite carbonyl iron		Conductive polyethylene foam				Resistor film	Plastic ferrite
Anechoic chamber	EMI, EMS	20MHz to 1GHz	○												
	Equivalent-to-ground floor	20MHz to 6GHz	○	○											
Prevents ghost disturbance	TV, VOR	80 to 220MHz	○												
	TV	470 to 770MHz	○												
	Railroad radio	400 to 500MHz		○											
	SSR	1030, 1090MHz			○										
Prevention radio communication disturbance	Mobile phones and water vessels	0.7 to 3GHz			○	○				○	○				
	Water vessels and various radios	3 to 10GHz				○									
Prevention false radar image	Water vessels and various radios	8 to 16GHz					○								
	Various radios	10 to 30GHz						○							
ETC, ITS	DSRC	5.8GHz				○	○					○	○	○	○
Wireless LAN	IEEE802.11b,g	2.4GHz				○							○		
	IEEE802.11a	5.2GHz					○								

- ○: Recommended material, ○: Semi-recommended material
- Upon request, we design products with frequency responses other than those stated above as well as products that support oblique incidence.
- TDK reserves the right to determine the product name based on the design completed in response to your request.

FOR EMC ANECHOIC CHAMBERS

IP MATERIAL

Made of base material of styrofoam combined with IP radio wave absorber, which is known for its ohmic loss properties, and IB material, which is a ferrite radio wave absorber, these products were developed for anechoic chambers.

Our composite absorbers fully utilize the features of each loss material. In the 30 to 500MHz range the IB electromagnetic absorbers, and in the higher range of 500MHz and higher the IP electromagnetic absorbers, are designed to provide efficient electromagnetic absorption and deliver excellent electromagnetic absorption performance for frequencies as low as 30MHz.

IP-090BLA, IP-130BL

TDK's composite electromagnetic absorbers are highly praised around the world. These unit-configured electromagnetic absorbers are small, light weight, inexpensive and deliver excellent electromagnetic absorption performance over a wide bandwidth. They are used widely in anechoic chambers for 3- to 5-meter test ranges as well as in large anechoic chambers designed for specific applications.

FEATURES

- Ultra-wideband electromagnetic absorber
- Stable against acids, bases and water vapor, and offers long service life.
- Uses materials that, when burned, emit gases that are relatively harmless to humans.
- Fire retardant (NRL Classes 1, 2 and 3; UL-94HF-1).
- White end caps (sold separately) improve the illumination inside the chamber.

STANDARD MATERIALS

Material name	Length (cm)	Standard weight (kg)	Applicable anechoic chambers
IP-045C	45	4	Compact(3-meter test range), 3-meter test range (EMS floors available)
IP-065BL	65	3.5	3-meter and 10-meter test ranges
IP-090BLA	93	5	3-meter and 10-meter test ranges
IP-130BL	128	7	10-meter test ranges



PRODUCT IDENTIFICATIONS

I P - 090 BL A
 (1) (2) (3) (4) (5)

- (1) TDK electromagnetic absorbers
- (2) Base material (P: Styrofoam)
- (3) Length dimensional code(090: 93cm)
- (4) Structure code
- (5) Version code

SHAPES AND DIMENSIONS

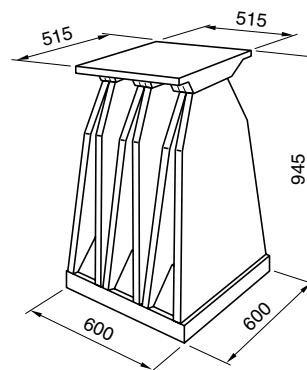

Dimensions in mm

TYPICAL ABSORPTION CHARACTERISTICS (VERTICAL INCIDENCE)

Unit: dB

Material name	30MHz	50MHz	100MHz	500MHz	1GHz	5GHz	18GHz	40GHz
IP-045C	15	18	18	20	20	30	40	40
IP-065BL	18	22	18	20	20	25	20	20
IP-090BLA	20	25	20	20	23	40	40	40
IP-130BL	24	25	22	23	25	40	40	40

- Representative power withstand performance: 70mW/cm²(200v/m tests can be used)

- All specifications are subject to change without notice.
- It may not be allowed to export these absorbers due to Export Control regulations.

FOR EMC ANECHOIC CHAMBERS

ICM MATERIAL

This is a composite electromagnetic absorber that utilizes the characteristics of the ICM electromagnetic absorber, which is a composite magnetic loss object made of an inorganic base and ferrite powder, and the IB electromagnetic absorber that utilizes the magnetic loss of ferrite.

Our composite absorbers fully utilize the features of each loss material. In the 30 to 500MHz range the IB electromagnetic absorbers, and in the higher range of 500MHz and higher the ICM electromagnetic absorbers, are designed to provide efficient electromagnetic absorption and deliver excellent electromagnetic absorption performance for frequencies as low as 30MHz.



ICM-006

This is a 6-cm long composite electromagnetic absorber for ECM anechoic chambers. The absorber is small but provides excellent electromagnetic absorption performance starting at low frequencies. This product is optimally suited for anechoic chambers with 3-m test ranges and small chambers.

Additionally, because all of these products are composed of inorganic material, they are suited for high-power irradiation tests during EMS tests.

FEATURES

- Ultra-wideband electromagnetic absorber
- Composed of inorganic material and offers long service life.
- Composed of inorganic material and is nonflammable.
- Suited for high-power irradiation tests.

STANDARD MATERIALS

Material name	Length (cm)	Standard weight (kg)	Applicable anechoic chambers
ICM-006	6	0.8	Compact(3-meter test range), 3-meter and 10-meter test ranges(EMS floors available)

PRODUCT IDENTIFICATIONS

I	C	M	-	006
(1)	(2)	(3)	(4)	

- (1) TDK electromagnetic absorbers
- (2) Base material(C: Inorganic material)
- (3) Ferrite material
- (4) Length dimensional code(006: 6cm)

SHAPES AND DIMENSIONS

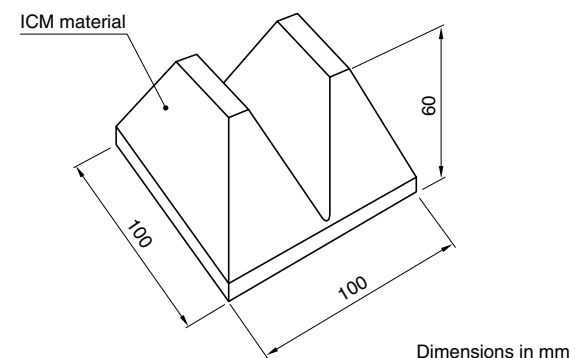

Notes

- Perforated IB electromagnetic absorbers are used.
- Screws are sometimes used to install items to the ceiling and walls.

TYPICAL ABSORPTION CHARACTERISTICS (VERTICAL INCIDENCE)

Material name	30MHz	50MHz	100MHz	500MHz	1GHz	5GHz	10GHz	18GHz
ICM-006	15	20	20	20	20	20	20	20

Unit: dB

FOR EMC ANECHOIC CHAMBERS

IB MATERIAL

This electromagnetic absorber utilizes the magnetic resonance loss characteristic of ferrite. This sintered ferrite has been baked at a temperature of over 1000°C and possesses physical properties equivalent to those of external porcelain tiles. In addition to EMC anechoic chambers, these products can be used in a wide range of applications including TV ghost prevention, as well as protection for aeronautical and railroad radios.

IB-015

This is a Ni-Cu-Zn sintered ferrite and delivers excellent electromagnetic absorption performance particularly in the VHF band. This extremely thin electromagnetic absorber is only approximately 6-mm thick.

It is optimally suited for applications in EMC anechoic chambers, TV ghost prevention and protection against interference for aeronautical radio.

In addition to the IB-015, our line up includes IB-003 and IB-004 that deliver excellent electromagnetic absorption performance in the UHF band.

FEATURES

- This is a thin-type wide-band electromagnetic absorber.
- This is highly weather resistant.
- Can be used as building material.

PRODUCT IDENTIFICATIONS

I B - 015
(1) (2) (3)

- (1) TDK electromagnetic absorbers
(2) Base material(B: Sintered ferrite)
(3) Material code

PHYSICAL PERFORMANCES

Bending strength(Pa)	5.4×10^7
Tensile strength(Pa)	4.4×10^6
Compression hardness(Pa)	2.4×10^8
Thermal expansion coefficient($^{\circ}\text{C}^{-1}$)	$(6 \text{ to } 10) \times 10^{-6}$
Thermal conductivity $\text{W}/(\text{m} \cdot ^{\circ}\text{C})$	6
Specific heat $\text{J}/(\text{kg} \cdot ^{\circ}\text{C})$	840

STANDARD MATERIALS

Material name	Standard dimensions (mm)	Standard weight (g)	Applications
IB-015	100×100×6.3	320	EMC anechoic chambers, TV ghost prevention and protection for aeronautical radio
IB-003	60×60×7.0	110	EMC anechoic chambers and protection for railroad radio
IB-004	60×60×4.2	80	False echo prevention for aeronautical radars and mobile phone inspection dark boxes

- We also design electromagnetic absorbent panels for TV ghost prevention. Please call for a consultation.



REFLECTION ATTENUATION vs. FREQUENCY CHARACTERISTICS(Measured using coaxial tube)
IB-015

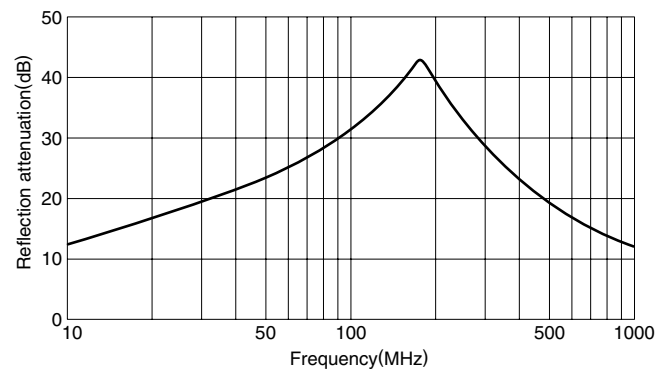

IB-003

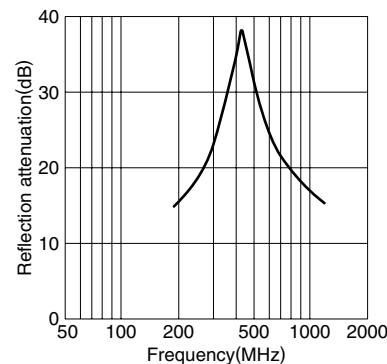

IB-004

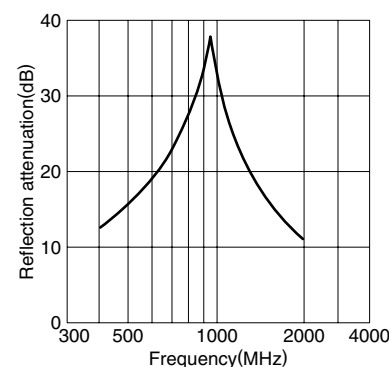

- All specifications are subject to change without notice.
- It may not be allowed to export these absorbers due to Export Control regulations.

FOR EMS FLOORS

IS-S MATERIAL

This electromagnetic absorber consists of a polyethylene foam base and utilizes the ohmic loss of carbon. Specifically designed for oblique incidence, the IS-S electromagnetic absorber provides excellent oblique incidence characteristics and can be used as electromagnetic absorbent flooring material for EMS tests from frequencies as low as 80MHz. It can also be used in microwave anechoic chambers.



IS-080S

This is a specially designed wedged-shaped absorber with a length of 80cm. It can be used as electromagnetic absorbent flooring material for EMS tests from frequencies as low as 80MHz. It delivers excellent oblique incidence performance starting at low frequencies.

PRODUCT IDENTIFICATIONS

I S - 080 S
(1) (2) (3) (4)

- (1) TDK electromagnetic absorbers
- (2) Base material (S: Polyethylene foam)
- (3) Length dimensional code(080: Approximate 80cm)
- (4) For diagonal incidence

SHAPES AND DIMENSIONS

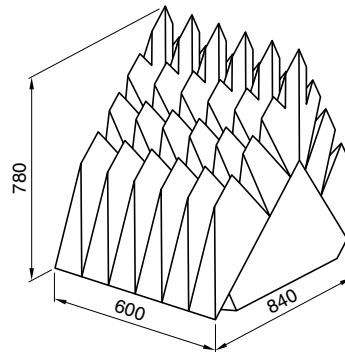

Dimensions in mm

TYPICAL ABSORPTION CHARACTERISTICS (45° INCIDENCE ANGLE)

Unit: dB

Material name		80MHz	100MHz	300MHz	500MHz	800MHz	1GHz	2GHz	3GHz
IS-080S	TE	15	15	25	27	35	35	37	55
	TM	15	15	25	27	30	35	40	55

- Representative power withstand performance: 100mW/cm²(200v/m tests can be used)

FOR MICROWAVE ANECHOIC CHAMBERS

IS MATERIAL

This electromagnetic absorber consists of a polyethylene foam base and utilizes the ohmic loss of carbon. Not only is the IS electromagnetic absorber capable of absorbing microwaves, it also delivers excellent electromagnetic absorption performance through millimeter and submillimeter waves (through 1THz).

IS-030A

This is a 30-cm long pyramidal electromagnetic absorber. It delivers excellent electromagnetic absorption performance over a wide band between 0.8 and 110GHz. It is optimally suited for applications in a wide range of wireless access applications and microwave anechoic chambers for conducting cellular phone related tests.

FEATURES

- Ultra-wideband electromagnetic absorber
- Excellent electromagnetic absorption performance in the millimeter wave band.
- The tip is designed to reduce creep and deliver stable performance.
- Stable against chemicals and offers long service life.
- Uses materials that, when burned, emit gases that are relatively harmless to humans.
- Fire retardant (NRL Classes 1, 2 and 3; UL-94HBF).
- Walking material are also available.
- Available white end caps can be used to improve the indoor illumination.

PRODUCT IDENTIFICATIONS

I S - 030 A
 (1) (2) (3) (4)

- (1) TDK electromagnetic absorbers
- (2) Base material(S: Polyethylene foam)
- (3) Length dimensional code(030: 30cm)
- (4) Version code

TYPICAL ABSORPTION CHARACTERISTICS (VERTICAL INCIDENCE)

Unit: dB

Material name	Length(mm)	0.3GHz	0.5GHz	0.8GHz	1GHz	3GHz	5GHz	10GHz	30GHz	50GHz	110GHz
IS-005A	50	—	—	—	—	15	20	30	50	50	50
IS-012A	120	—	—	20	20	30	40	55	55	55	50
IS-015A	150	—	—	20	20	35	40	55	55	55	50
IS-023A	230	—	—	23	30	45	50	55	55	55	50
IS-030A	300	—	—	30	35	45	50	55	55	55	50
IS-045	450	—	30	35	40	45	50	55	55	55	50
IS-060	600	—	32	37	42	50	55	55	55	55	50
IS-075	750	25	35	40	45	55	55	55	55	55	50
IS-100	1000	30	40	45	50	55	55	55	55	55	50

• Representative power withstand performance: 100mW/cm²

ABSORBERS FOR WALKING MATERIAL

PRODUCT IDENTIFICATIONS

I S - ○○○ FL
 (1) (2) (3) (4)

- (1) TDK electromagnetic absorbers
- (2) Base material(S: Polyethylene foam)
- (3) Length dimensional code
- (4) Type(FL: walking material)

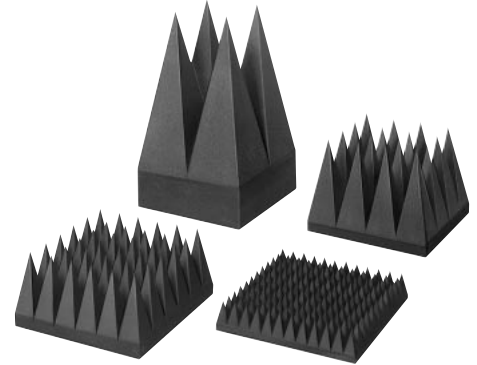

SHAPES AND DIMENSIONS

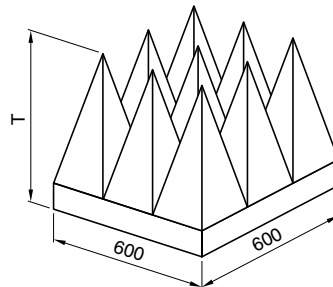

Dimensions in mm

SHAPES AND DIMENSIONS

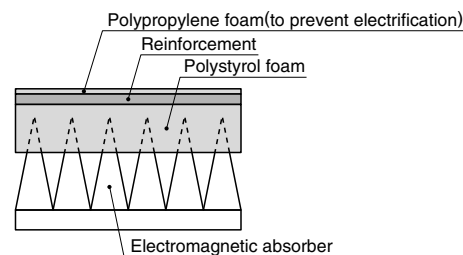

- All specifications are subject to change without notice.
- It may not be allowed to export these absorbers due to Export Control regulations.

DESIGNED SPECIFICALLY FOR OBLIQUE INCIDENCE FOR USE IN MICROWAVE ANECHOIC CHAMBERS

IS-SM MATERIAL

This electromagnetic absorber consists of a polyethylene foam base and utilizes the ohmic loss of carbon. Not only is the IS-SM absorber, which is designed specifically for oblique incidence, capable of absorbing microwaves, it also delivers excellent electromagnetic absorption performance through millimeter waves.

IS-SM050

This is a special pyramidal electromagnetic absorber with a length of 50cm. It provides excellent oblique incidence characteristics for a wide band between 0.8 and 110GHz. It is optimally suited for applications in a wide range of wireless access operations and as sidewall panels in microwave anechoic chambers for conducting cellular phone related tests. It is also optimally suited to be used as CISPR compliant electromagnetic absorbent floor material for the 1GHz plus range. Our line up includes IS-SM080 and IS-SM100 that deliver excellent electromagnetic absorption performance starting at low frequency ranges.

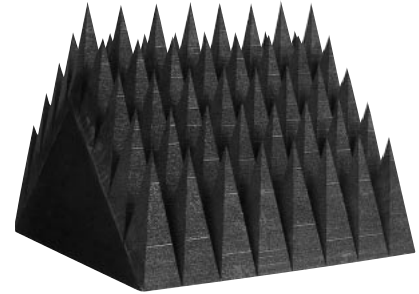

FEATURES

- Ultra-wideband electromagnetic absorber
- Excellent electromagnetic absorption performance for oblique incidences.
- The product can be made thinner than pyramidal absorbers.
- The tip is designed to reduce creep and deliver stable performance.
- Stable against chemicals and offers long service life.
- Uses materials that, when burned, emit gases that are relatively harmless to humans.
- Fire retardant (NRL Classes 1, 2 and 3; UL-94HBF).

PRODUCT IDENTIFICATIONS

I S - SM 050
(1) (2) (3) (4)

- (1) TDK electromagnetic absorbers
 (2) Base material(S: Polyethylene foam)
 (3) Designed specifically for oblique incidence. Supports millimeter waves.
 (4) Length dimensional code(050: 50cm)

STANDARD DIMENSIONS

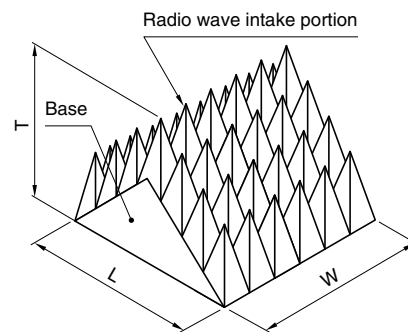

Material name	Standard dimensions(mm) [L×W×T]
IS-SM050	600×600×500
IS-SM080	840×600×800
IS-SM100	840×600×1000

TYPICAL ABSORPTION CHARACTERISTICS (50° INCIDENCE ANGLE)

Unit: dB

Material name		0.3GHz	0.5GHz	0.8GHz	1GHz	3GHz	5GHz	10GHz	30GHz	50GHz	110GHz
IS-SM050	TE	—	—	35	40	45	50	55	55	55	50
	TM	—	—	30	35	45	50	55	55	55	50
IS-SM080	TE	—	30	40	40	55	55	55	55	55	50
	TM	—	30	40	45	55	55	55	55	55	50
IS-SM100	TE	30	35	40	45	55	55	55	55	55	50
	TM	20	30	40	45	55	55	55	55	55	50

- Representative power withstand performance: 100mW/cm²

FOR FM BAND AND MICROWAVE ANECHOIC CHAMBERS

IP-BX MATERIAL

This is a composite electromagnetic absorber made by combining the IP-BX electromagnetic absorber, which consists of a styrofoam base and utilizes the ohmic loss of carbon, and an electromagnetic absorber that uses the magnetic loss of ferrite. Each of the loss material are matched for impedance to deliver excellent electromagnetic absorption performance from as low as the 70MHz FM band.



IP-100BX, IP-130BX

These TDK composite electromagnetic absorbers have been praised highly in tests for automobile antennas. IP-100BX delivers excellent electromagnetic absorption performance for vertical incidences starting at the FM band to the microwave range. IP-130BX delivers excellent electromagnetic absorption performance for oblique incidences starting at the FM band to the microwave range. These products are used widely in anechoic chambers for testing automobile antennas and large special purpose anechoic chambers.

FEATURES

- Ultra-wideband electromagnetic absorber
- Stable against acids, bases and water vapor, and offers long service life.
- Uses materials that, when burned, emit gases that are relatively harmless to humans.
- Fire retardant (NRL Classes 1, 2 and 3; UL-94HF-1).

PRODUCT IDENTIFICATIONS

I P - 130 B X
(1) (2) (3) (4) (5)

- (1) TDK electromagnetic absorbers
- (2) Base material(P: Styrofoam)
- (3) Length dimensional code(130: 130cm)
- (4) Version code
- (5) Ferrite material

SHAPES AND DIMENSIONS

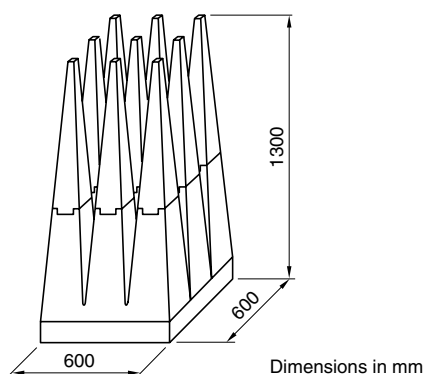

STANDARD MATERIALS

Material name	Length (cm)	Standard weight (kg)	Shapes
IP-045BX	45	4	Wedge form
IP-100BX	100	8	Wedge form
IP-130BX	130	9	Pyramid form

TYPICAL ABSORPTION CHARACTERISTICS (VERTICAL INCIDENCE)

Unit: dB

Material name	70MHz	80MHz	100MHz	500MHz	1GHz	5GHz	18GHz	40GHz
IP-045BX	23	25	23	20	22	25	40	40
IP-100BX	25	30	30	30	30	40	40	40

TYPICAL ABSORPTION CHARACTERISTICS (60° INCIDENCE ANGLE)

Unit: dB

Material name		70MHz	80MHz	100MHz	500MHz	1GHz	5GHz	18GHz	40GHz
IP-130BX	TE	10	10	12	35	45	50	50	50
	TM	20	20	20	35	45	50	50	50

- Representative power withstand performance: 70mW/cm²(200v/m tests can be used)

- All specifications are subject to change without notice.
- It may not be allowed to export these absorbers due to Export Control regulations.

FOR EMC/MICROWAVE ANECHOIC CHAMBERS

IP MATERIAL

This is a composite electromagnetic absorber made by combining the IP electromagnetic absorber, which consists of a styrofoam base and utilizes the ohmic loss of carbon, and an electromagnetic absorber that uses the magnetic loss of ferrite. These composite absorbers fully utilize the features of each loss material. In ranges of 500MHz or lower the IB electromagnetic absorbers, and in the higher range of 500MHz and higher the IP electromagnetic absorbers, are designed to provide efficient electromagnetic absorption.

IP-045E

These TDK composite electromagnetic absorbers have been praised highly for their application in EMC/microwave tests. IP-045E delivers excellent electromagnetic absorption performance for vertical incidences starting at 30MHz to the microwave range.

Additionally, our line up includes IP-100B and IP-150B that deliver excellent electromagnetic absorption performance starting at low frequency ranges. These are optimally suited for six-sided anechoic chambers (for EN and ETSI compliance).



FEATURES

- Ultra-wideband electromagnetic absorber
- Stable against acids, bases and water vapor, and offers long service life.
- Uses materials that, when burned, emit gases that are relatively harmless to humans.
- Fire retardant (NRL Classes 1, 2 and 3; UL-94HF-1).

PRODUCT IDENTIFICATIONS

I P - 100 B
(1) (2) (3) (4)

- (1) TDK electromagnetic absorbers
(2) Base material(P: Styrofoam)
(3) Length dimensional code(100: 100cm)
(4) Version code

SHAPES AND DIMENSIONS

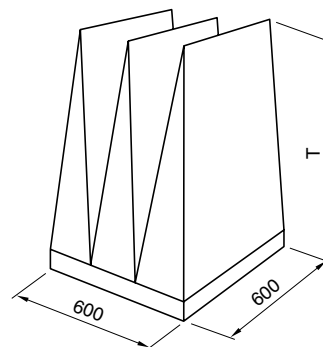

Dimensions in mm

STANDARD MATERIALS

Material name	Length (cm)	Standard weight (kg)	Applicable anechoic chambers
IP-045E	45	4	EMC and antenna evaluation etc.
IP-100B	100	8	EN compliant and ETSI compliant
IP-150B	150	12	EN compliant and ETSI compliant

TYPICAL ABSORPTION CHARACTERISTICS (VERTICAL INCIDENCE)

Unit: dB

Material name	30MHz	50MHz	100MHz	500MHz	1GHz	5GHz	18GHz	40GHz
IP-045E	14	14	14	20	30	40	40	40
IP-100B	17	17	18	25	30	40	40	40
IP-150B	20	23	30	30	32	40	40	40

- Representative power withstand performance: 70mW/cm²(200v/m tests can be used)

- All specifications are subject to change without notice.
- It may not be allowed to export these absorbers due to Export Control regulations.

FOR ANECHOIC CHAMBERS USED IN HIGH-POWER TESTS

ICT MATERIAL

This is a pyramidal electromagnetic absorber with a corrugated structure that consists of an inorganic base and utilizes the ohmic loss of carbon. The corrugated structure is designed to radiate heat efficiently during power irradiations of 1W/cm² or greater.

ICT-012

This is a 12-cm long pyramidal electromagnetic absorber with a corrugated structure.

It delivers excellent electromagnetic absorption performance over a wide band between 0.8 and 110GHz. Our line up includes ICT-030 that delivers excellent electromagnetic absorption performance starting at low frequency ranges. These products are optimally suited for anechoic chambers and small anechoic dark boxes used in high-power tests.

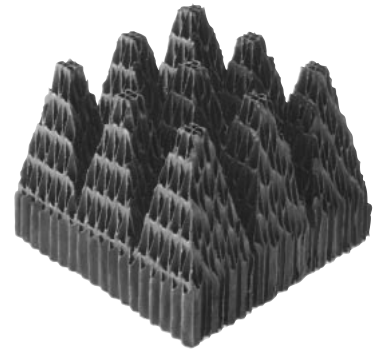

FEATURES

- Ultra-wideband electromagnetic absorber
- Excellent heat radiation for heat generated during high-power irradiation.
- Constructed of nonflammable materials to withstand the heat generated during high-power irradiation.
- Lightweight and strong

PRODUCT IDENTIFICATIONS

I C T - 012
(1) (2) (3) (4)

- (1) TDK electromagnetic absorbers
 (2) Base material(C: Inorganic material)
 (3) For high power
 (4) Length dimensional code(012: 12cm)

STANDARD MATERIALS

Material name	Standard dimensions(mm) [L×L×T]	Standard weight(kg)
ICT-012	150×150×120	0.35
ICT-030	300×300×300	3

SHAPES AND DIMENSIONS

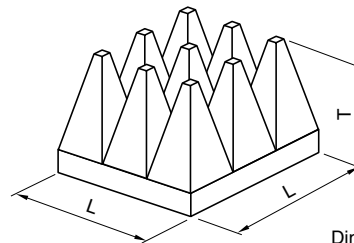

Dimensions in mm

TYPICAL ABSORPTION CHARACTERISTICS (VERTICAL INCIDENCE)

Material name	0.3GHz	0.5GHz	0.8GHz	1GHz	3GHz	5GHz	10GHz	30GHz	50GHz	110GHz	Unit: dB
ICT-012	—	—	15	20	25	30	35	40	40	35	
ICT-030	10	15	20	25	35	35	40	40	40	35	

EXAMPLE OF RESULTS FROM A HIGH-POWER IRRADIATION TEST

(Heat generation characteristics)

Material name	1.5W/cm ²	5W/cm ²
ICT-012	Tip: 140°C/Bottom: 80°C	—
ICT-030	Tip: 140°C/Bottom: 60°C	Tip: 300°C

- All specifications are subject to change without notice.
- It may not be allowed to export these absorbers due to Export Control regulations.

THIN TYPE

IR MATERIAL (IR-A AND IR-B ABSORBERS)

This is a composite ferrite electromagnetic absorber made by mixing ferrite powder into synthetic rubber. This product is flexible because it uses synthetic rubber as its base. By adjusting the ferrite composition and content, this product can be designed to respond to specific frequencies within the 0.7 to 8GHz microwave range.

IR-B024

This electromagnetic absorber is designed for the 2.4GHz band. It delivers excellent electromagnetic absorption performance and is optimally suited for improving communication environments including wireless LANs.

IR-A051

This electromagnetic absorber is designed for the 5.1GHz band. It delivers excellent electromagnetic absorption performance and is optimally suited for improving communication environments including wireless LANs.



FEATURES

- Excellent electromagnetic absorption performance.
- Flexible and easy to work with.
- Can be designed for various purposes.

PRODUCT IDENTIFICATIONS

$\frac{\text{I}}{(1)} \frac{\text{R}}{(2)} - \frac{\text{B}}{(3)} \frac{\text{024}}{(4)} \frac{\text{300} \times \text{300}}{(5)} \times \frac{\text{T}}{(6)}$

- (1) TDK electromagnetic absorbers
- (2) Base material(R: Synthetic rubber)
- (3) Ferrite material
- (4) Center frequency(024: 2.4GHz)
- (5) Dimensions(mm)
- (6) Thickness dimensions(mm)

REFLECTION ATTENUATION vs. FREQUENCY CHARACTERISTICS

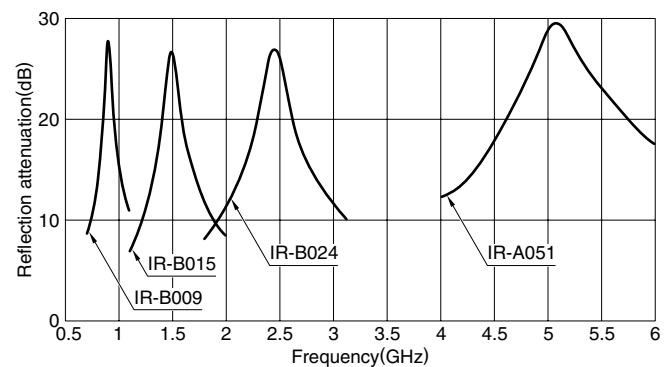

STANDARD MATERIALS AND TYPICAL ABSORBENT CHARACTERISTICS

Material name	Center frequency (GHz)	20dB bandwidth (GHz)	Standard thickness T (mm)	300×300mm standard weight (kg)	Application
IR-B009	0.9	0.08	8.4	2.4	Cellular phone
IR-B015	1.5	0.15	6.8	1.8	Prevents false echos in radars.
IR-B024	2.4	0.35	5.9	1.4	Wireless LAN
IR-A051	5.1	1.10	5.3	1.2	Wireless LAN

- All specifications are subject to change without notice.
- It may not be allowed to export these absorbers due to Export Control regulations.

THIN TYPE

IR MATERIAL (IR-E ABSORBER)

This is a composite magnetic radio wave absorber made by mixing carbonyl iron powder into synthetic rubber. This product is flexible because it uses synthetic rubber as its base. By adjusting the carbonyl iron powder content, this product can be designed to respond to specific frequencies within the 10 to 26GHz microwave range.

IR-E240

This electromagnetic absorber is designed for the 24GHz band. It delivers excellent electromagnetic absorption performance and is optimally suited for improving communication environments including wireless access.



FEATURES

- Excellent electromagnetic absorption performance.
- Flexible and easy to work with.
- Can be designed for various purposes.

PRODUCT IDENTIFICATIONS

I R - E 240 300x300 × T
 (1) (2) (3) (4) (5) (6)

- (1) TDK electromagnetic absorbers
- (2) Base material(R: Synthetic rubber)
- (3) Carbonyl iron
- (4) Center frequency(240: 24GHz)
- (5) Dimensions(mm)
- (6) Thickness dimensions(mm)

STANDARD MATERIALS AND TYPICAL ABSORBENT CHARACTERISTICS

Material name	Center frequency (GHz)	20dB bandwidth (GHz)	Standard thickness T (mm)	300×300mm standard weight (g)
IR-E110	11	1.5	1.5	495
IR-E140	14	1.5	1.3	450
IR-E240	24	2.0	0.9	435

REFLECTION ATTENUATION vs. FREQUENCY CHARACTERISTICS

IR-E110

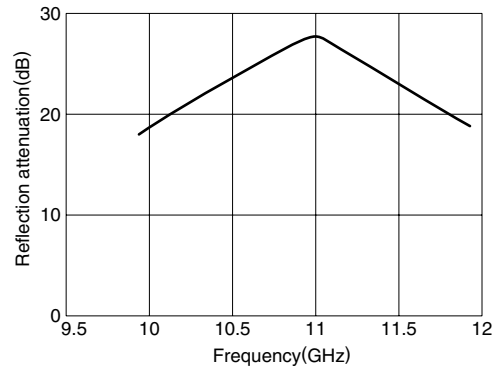

IR-E240

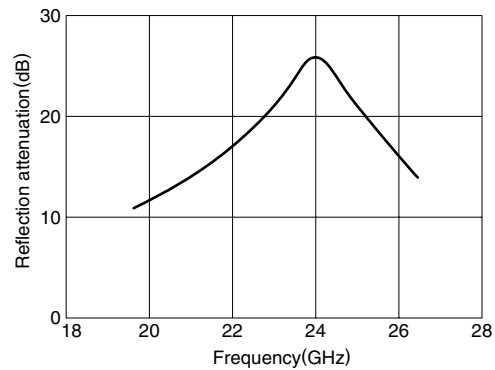

- All specifications are subject to change without notice.
- It may not be allowed to export these absorbers due to Export Control regulations.

THIN TYPE

IR MATERIAL (IR-K ABSORBER)

This is a composite ferrite electromagnetic absorber made by mixing hexagonal ferrite powder into synthetic rubber. This product is flexible because it uses synthetic rubber as its base. By adjusting the hexagonal ferrite composition and content, this product delivers wide-band electromagnetic absorption performance within the X to Ku band.



IR-K090

This electromagnetic absorber is designed for the X band. It delivers excellent electromagnetic absorption performance and is optimally suited for use on masts of water vessels and bridges to prevent false echos.

FEATURES

- Excellent electromagnetic absorption performance over a wide band.
- Flexible and easy to work with.
- Can be designed for various purposes.

PRODUCT IDENTIFICATIONS

I R - K 090 300×300 × T
 (1) (2) (3) (4) (5) (6)

- (1) TDK electromagnetic absorbers
- (2) Base material(R: Synthetic rubber)
- (3) Ferrite material
- (4) Center frequency(090: 9GHz)
- (5) Dimensions(mm)
- (6) Thickness dimensions(mm)

STANDARD MATERIALS AND TYPICAL ABSORBENT CHARACTERISTICS

Material name	Center frequency (GHz)	20dB bandwidth (GHz)	Standard thickness T (mm)	300×300mm standard weight (g)
IR-K090	9	2.5	2.2	470
IR-K150	15	5.0	2.0	405
IR-K160	16	3.0	1.9	245

REFLECTION ATTENUATION vs. FREQUENCY CHARACTERISTICS

IR-K090

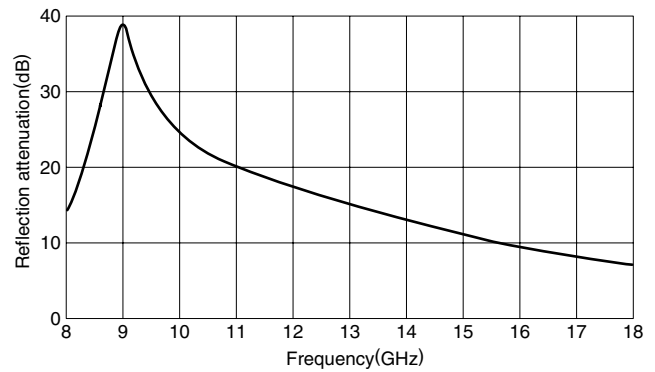

IR-K150

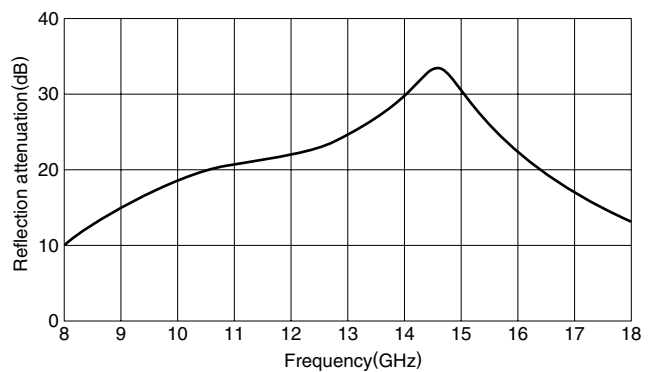

- All specifications are subject to change without notice.
- It may not be allowed to export these absorbers due to Export Control regulations.

THIN TYPE

ISF MATERIAL

This flat plate electromagnetic absorber is made of a polyethylene foam base and utilizes the ohmic loss of carbon. This absorber delivers excellent electromagnetic absorption performance due to its structure, which consists of laminations of materials with different carbon contents. It is lightweight due to its polyethylene foam base. It is highly weather resistant making it a good choice for outdoor applications. This product can be designed to respond to specific frequencies.

IS-FB75

This electromagnetic absorber is designed for the 0.8 to 1.8GHz band for mobile phones. It delivers excellent electromagnetic absorption performance for vertical incidences.

ISFE27F5

This electromagnetic absorber is designed for the 5.8GHz band. It delivers excellent electromagnetic absorption performance even at steep oblique incidences and is optimally suited for improving ETC and DSRC communication environments. This product is used widely on the ceilings of ETC toll gates and other facilities.

FEATURES

- Excellent electromagnetic absorption performance in the micro-wave range.
- Lightweight and easy to work with.
- Fire retardant (NRL Classes 1, 2 and 3; UL-94HBF).
- Provides excellent weather resistance and can be used outdoors. Please consult us for outdoor applications.
- Can be designed for various purposes.

STANDARD MATERIALS AND TYPICAL ABSORBENT CHARACTERISTICS

Material name	Center frequency (GHz)	Typical absorbent characteristics (dB)	Standard thickness T(mm)	Standard weight (kg/m ²)	Applications
IS-FB75	0.8 to 1.9	15	79	4.5	Cellular phone
ISFA24	2.4	15	24	1.7	Wireless LAN
ISFE27F5	5.8	20	32	2.2	ETC, DSRC

- ETC/DSRC electromagnetic absorbent panels using ISFE27F5 were co-developed by Sekisui Jushi Corporation. Please note that these products are not sold alone.
- Upon request, we design products with frequency responses other than those stated above as well as products that support oblique incidence.
- TDK reserves the right to determine the product name.

COMPOSITION EXAMPLE OF RADIO WAVE ABSORBERS

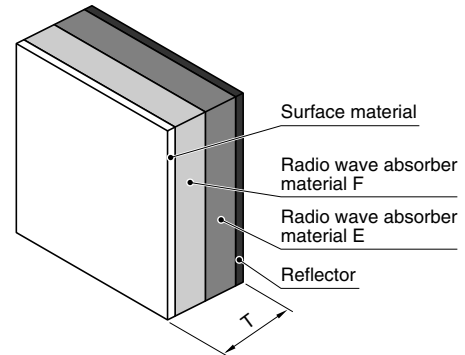

PRODUCT IDENTIFICATIONS

I	S	F	E27	F5
(1)	(2)	(3)	(4)	(5)

- (1) TDK electromagnetic absorbers
- (2) Base material(S: Polyethylene foam)
- (3) Flat plate
- (4) Material and thickness(E27: E material 27mm)
- (5) Material and thickness(F5: F material 5mm)

THIN TYPE

IJ MATERIAL

This is a composite ferrite electromagnetic absorber made by mixing ferrite powder into straight-chain polyethylene resin. This product can also be used outdoors because it is made of a straight-chain polyethylene base and is highly weather resistant.

By adjusting the ferrite composition and content, this product can be designed to respond to specific frequencies. For high frequency support, we also design composite magnetic radio wave absorbers containing carbonyl iron.

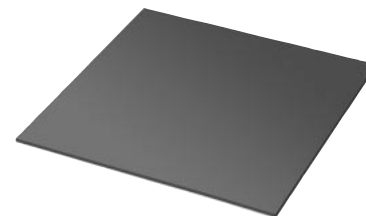

IJ-B058

This electromagnetic absorber is designed for the 5.8GHz band. It delivers excellent electromagnetic absorption performance even for acute oblique incidences and is optimally suited for improving ETC and DSRC communication environments. This product is used widely in areas around ETC toll gates and other facilities.

FEATURES

- Excellent weather resistance.
- Can be used outdoors.
- Is somewhat flexible.
- Can be attached with screws.
- Can be designed for various purposes.

PRODUCT IDENTIFICATIONS

I	J	- B	058
(1)	(2)	(3)	(4)

- (1) TDK electromagnetic absorbers
- (2) Base material(J: Straight-chain polyethylene)
- (3) Ferrite material
- (4) Center frequency(058: 5.8GHz)

STANDARD MATERIALS AND TYPICAL ABSORBENT CHARACTERISTICS

Material name	Center frequency (GHz)	20dB bandwidth (GHz)	Standard thickness T (mm)	Standard weight (kg/m ²)	Applications
IJ-B058	5.8	0.9	3.8	7.7	ETC/DSRC

- Please note that ETC/DSRC electromagnetic absorbers using IJ-B058 are not sold alone.
- Upon request, we design products with frequency responses other than those stated above.
- TDK reserves the right to determine the product name.
- Minimum order: 200m²

TRANSPARENT ELECTROMAGNETIC ABSORBER

ITB MATERIAL

This electromagnetic absorber uses a transparent conductive film and is designed for $\lambda/4$ electromagnetic absorbers. The film uses a PET (polyethylene terephthalate) base on which a film of ITO (indium tin oxide) is formed. Its visible ray transmissivity exceeds 70%.

ITB010, ITB390

ITB010 is a transparent conductive film designed to reflect radio waves and ITB390 is a transparent conductive film designed to absorb radio waves.

TRANSPARENT ELECTROMAGNETIC ABSORBENT PANEL

Designed for the 5.8GHz band, this $\lambda/4$ electromagnetic absorber uses a PC (polycarbonate) plate as a spacer. It is highly transparent with a visible ray transmissivity of over 60%.

It is optimally suited for improving ETC and DSRC communication environments.

COMPOSITION EXAMPLES OF TRANSPARENT ELECTROMAGNETIC ABSORBER

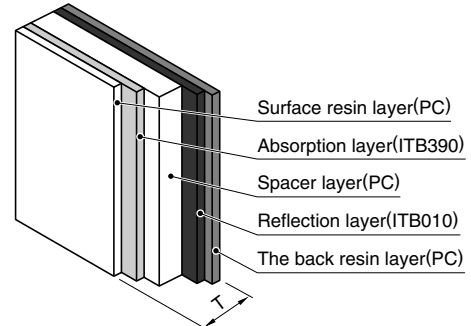

TRANSPARENT ELECTROMAGNETIC ABSORBER FEATURES

- Highly transparent with a visible ray transmissivity of over 60%.
- Designed for the 5.8GHz band.
- Will not shatter when subjected to shock.
- Can be designed for various purposes.

PRODUCT IDENTIFICATIONS

I TB 010

(1) (2) (3)

- (1) TDK electromagnetic absorbers
- (2) Base material(TB: Transparent electric conductive layer)
- (3) Planar resistance(010: 10 Ω /square)

STANDARD MATERIALS

Material name	Planar resistance (Ω /square)	Film width (cm)	Applications
ITB010	10	100	ETC, DSRC
ITB390	390	100	ETC, DSRC

- Please note that transparent conductive films are not sold alone.
- Transparent electromagnetic absorbent panels were co-developed by Sekisui Jushi Corporation. Upon request, we design products with frequency responses other than those stated above as well as products that support oblique incidence.

REFLECTION ATTENUATION vs. FREQUENCY CHARACTERISTICS

